



Instructions for Use and Maintenance

Chain Mulcher M-160



Note! Read instructions before use.



TREJON AB
Företagsvägen 9
SE-911 35 VÄNNÄSBY
SWEDEN
Tel: + 46 (0)935 39 900
Fax: + 46 (0)935 39 919



SAFETY SYMBOLS

Note! This warning symbol is used throughout this instruction manual to call attention to safety precautions that you, your employees or any other people that may come near the implement must read and understand. Failure to follow these instructions may result in serious injury or even death.

This symbol means:



**WARNING!
CAUTION!
YOUR SAFETY IS
ENDANGERED!**

A word of advice

Pay special attention to the words **WARNING!** and **CAUTION!** in the safety instructions. The words have been chosen from of the following:



WARNING! This safety sign is used to identify potential hazards that can lead to serious injury or even death. These hazards include situations that may occur when the safety equipment and/or the safety shields are removed. Signal words can also be used to alert about dangerous use.



CAUTION!: Failure to observe this warning sign could result in light personal injuries. The sign is also used to indicate that the disregarding of these instructions may cause damage to the implement.

Dear Customer,

Thank you for choosing TREJON. We hope that you are satisfied with your choice.

By reading the manual and following it's recommendations you will ensure the long and effective use of the machine.

We have produced this manual for you to get a good understanding of the functioning of the machine and what safety and maintenance instructions to follow when working with it.

If any question should arise when using the machine or when reading this manual, you are welcome to contact us for further information.

TREJON AB
Företagsvägen 9
SE-911 35 Vännäsby
Sweden

Tel: + 46 (0)935 39 900
Fax: + 46 (0)935 39 919,
Repair parts: +46 (0)935 20241
Email: info@trejon.se
Website: www.trejon.se

Honoured retailer,

in order for the guarantee to be valid and to fulfill all legal requirements, we ask you to fill out the guarantee form together with the customer and return it to TREJON.

The guarantee is valid from the day the equipment is handed over to the customer.

Delivery checklist:



Check for damages caused in transporting. Inform the transporting company.	
Check if the cardan shaft is included.	
Check if a blade set and 10mm chains are included.	
Check the oil level in the gearbox. It should be over the line on the dipstick in the upper part of the gearbox. See section 5,4	
Check the belt tension with plates using the slits on the belt guards; 15kg=15mm See section 4,7	
Having gone through and explained to the customer, with the help of the manual, the startup, use and maintenance of the equipment and it's accessories.	
Fill out the guarantee form with the customer and send it to TREJON AB. It can be found as an attachment to this manual and as a copy on the last page.	
Instruction manual given to the customer.	

Enter the serialnumber of the machine to the right.	S/N:
---	------

■ TABLE OF CONTENT

1	Introduction.....	6
1.1	Foreword.....	6
1.2	Description	6
1.3	Detailed description	7
1.4	Technical data.....	8
1.5	Working tools	9
1.6	Right and left hand.....	9
2	Safety instructions	10
2.1	Safety precautions	10
2.2	Explanation of the symbols	12
3	Assembly.....	14
4	Operating the machine.....	14
4.1	Before start-up	14
4.2	Mounting variations.....	15
4.3	Adjusting the machine for front- /rear-mounting.....	15
4.4	Adapted machine for reverse drive tractor (optional).....	16
4.5	Attaching the machine to the tractor	16
4.6	Pulleys with "Taper-Lock" clamp bushing	18
4.7	Tightening of the transmission V-belts.....	20
4.8	Support rollers for V-belt transmission.....	23
4.9	Adjust and change the cutting head chains	24
4.10	Installing the blade set	26
4.11	Transport the cutter.....	27
4.12	Cutting height and tools	27
4.13	Obstacle release mechanism.....	28
4.14	Operating the implement.....	29
4.15	Parking and storing the machine	31

5	Service and maintenance	31
5.1	Torque settings	31
5.2	Inspections and service measures after the first operation hours.....	31
5.3	Scheduled inspection.....	32
5.4	Checking the angle gearbox oil level	32
5.5	Oil change in the angle gearbox	33
5.6	Before the season starts	33
5.7	After the season ends.....	34
6	Troubleshooting	34
7	Spare parts list	35
7.1	Cutting head and transmission	36
7.2	Suspension frame and transmission.....	39

1 Introduction

1.1 Foreword

Thank you for choosing this OPTIMAL chain mulcher. We have concentrated our efforts in order to develop a sturdy machine that will operate trouble-free for many years. The working life of the machine, however, depends not only on us but also on you. We have compiled this instruction manual in order to facilitate the use of the implement and describe proper maintenance procedures. Read these instructions carefully. Contact the retailer from whom you purchased the machine whenever you want to order repair parts or need any other assistance. When you are ordering repair parts, make sure that you know the right model, type and serial number. See the plate on the chassis.

1.2 Description

This machine is intended to keep roadsides, ditches, fields and other areas clear from grass, bushes and shrubs. The cutting head can be equipped with different tools depending on the work to be done. The table below provides guidelines for choosing the proper tools.

Type of material	Tools		
	Blades	10mm chain	13mm chain
Lay lands, fields	+	+	+
Old fields	+	+	+
Old fields with small shrubs	+	+	+
Shrubs and bushes			+
Roadways and ditches			+

The machine is intended for farm tractors with a 3-point lift, cat. II. The mulcher is delivered in a standard design adjusted for rear-mounting on a tractor (puller).

The standard mulcher can be adjusted for front-mounting on the tractor. The power take-off at the front of a tractor usually rotates in a direction opposite to that of the power take-off at the back of a tractor. Because of this a cardan shaft with over running clutch for converse rotation direction (optional) is required. Check the rotational direction of the tractor's power take-off when front mounting the machine. If the tractor's power take-off does not have breaks, an axel without overrunning clutch can be used.

The machine can be optionally delivered for rear-mounting on tractors with a converted driver's seat (reverse drive tractors).

Machines that are adjusted for reverse drive tractors with a converted driver's seat can only be rear-mounted on the tractor. Otherwise the tractor will rotate the mulcher's rotor in the wrong direction.

The transmission is driven by the tractor's power turn-off from min. 540 to max. 1000rpm. The number of revolutions of the chain/blade can be adjusted with regard to the material that is to be cut and tractor power.

1.3 Detailed description

OPTIMAL M-160

Front view

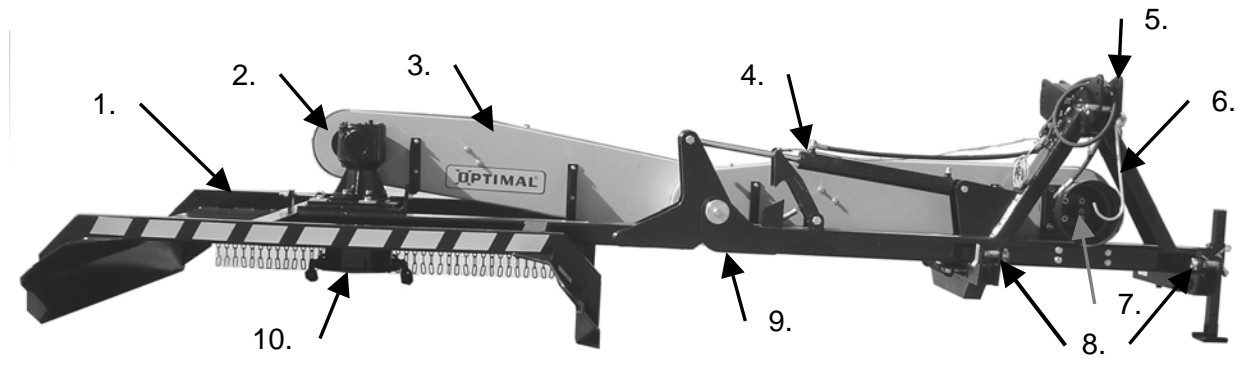

Rear view

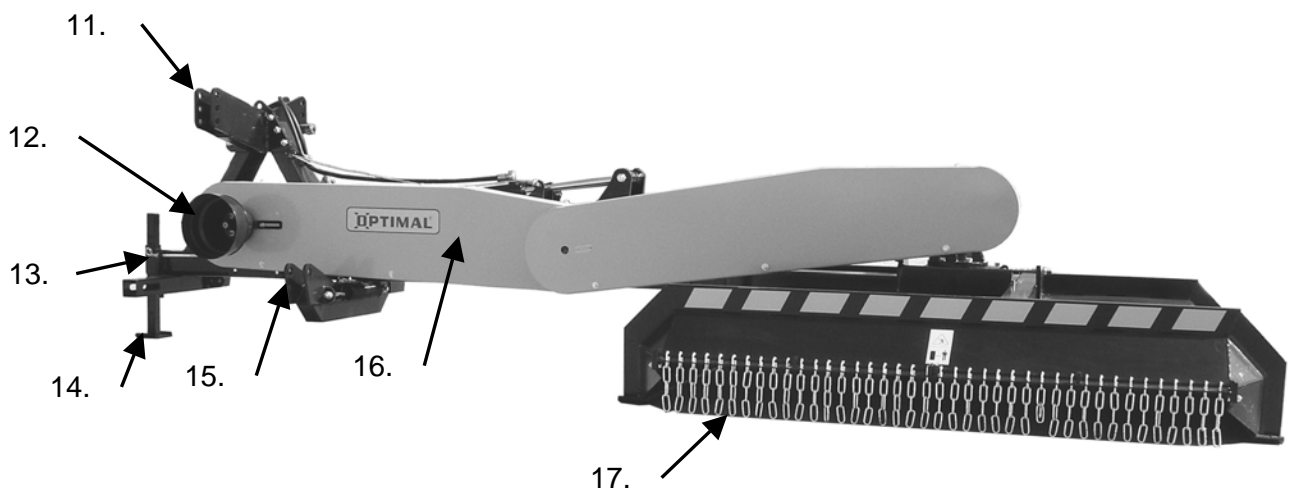

- | | |
|---|---|
| <ul style="list-style-type: none"> 1. Cutting head 2. Gear box 3. V-belt covers, cutting head 4. Hydraulic cylinder 5. Top link hitch point, rear mounting 6. PTO-shaft holder 7. Drive shaft, rear mounting 8. Lift arm hitch point, rear mounting 9. Joint 10. Chain holder | <ul style="list-style-type: none"> 11. Top link hitch point when front mounting/reverse drive tractor (optional) 12. Driving pin when front mounting/reverse drive tractor (optional) 13. Lift arm hitch point 14. Support leg 15. Obstacle release mechanism/Lift arm hitch point 16. V-belt covers, tractor hitch side 17. Chain curtain |
|---|---|

1.4 Technical data

OPTIMAL Chain mulcher.

Specifications / Model	M-160
Working width, ~cm	160
Chains/blades, number	2
Lift of cutting head, std. Type	Hydraulic
Hydraulic connections to tractor	1 single acting, ½" EURO
Weight, kg	800
3-point connection	Cat. II
Revolutions PTO, RPM	540-1000
Mounting alternatives, standard	*Front, pull type
Mounting alternatives, optional	For reverse drive tractors with converted driver's seat
Transmission to the gear box, type	SPB V-belts, 4 pcs
Transmission to chain rotor, type	Angle gearbox

With continuing product development the technical specifications are not binding and are subject to change without prior notice.

The figures in the table above can show non-standard equipment.

The standard of equipment may differ from country to country.

* When front-mounting a PTO shaft with converted rotation direction of the over running clutch is necessary (optional).

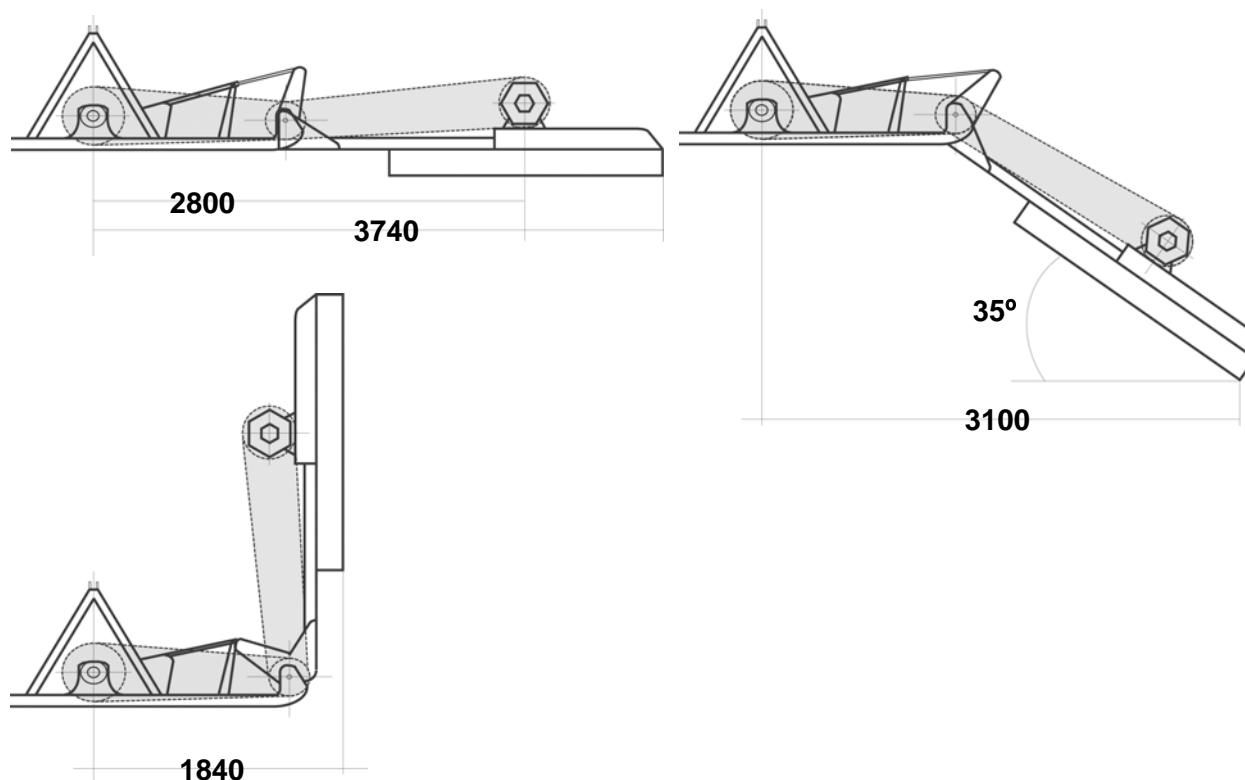

1.5 Working tools

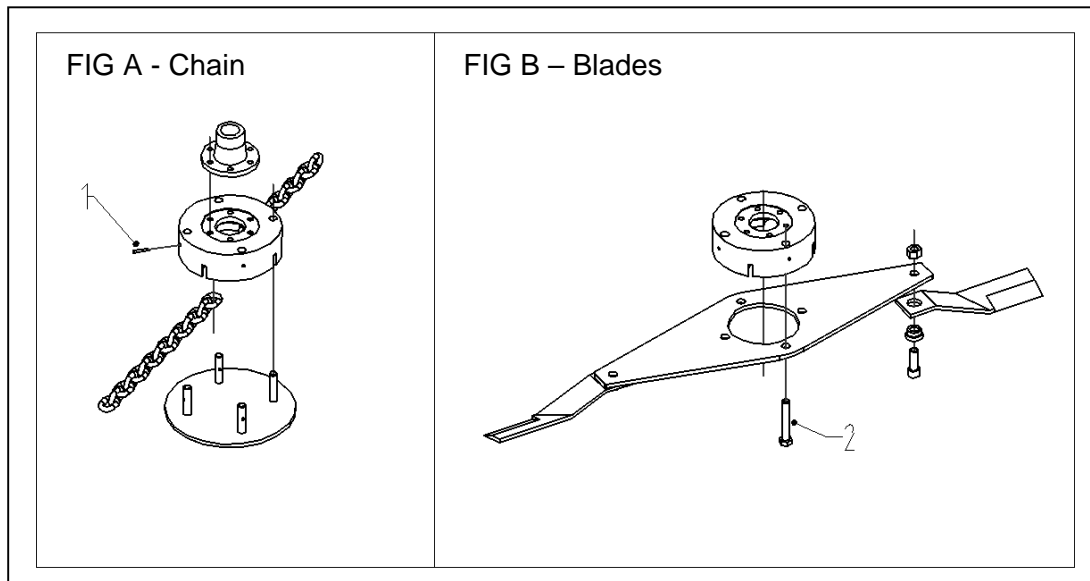

13mm chain, tempered, class 8

10mm chain, tempered, class 8

Blades (original)

1.6 Right and left hand

In this manual, the terms right and left hand refer to right and left as seen from the rear side of the tractor or from behind the tractor toward the direction of travel.

2 Safety instructions

2.1 Safety precautions



It is important that you follow these safety instructions during installation, maintenance, operation or other work on the machine.

Failure to read and follow these instructions can result in an increased risk of personal injury and/or property damage. The machine is intended only for outdoor use.



WARNING!

KEEP CLEAR OF THE WORKING AREA. NO PEOPLE OR ANIMALS ARE ALLOWED WITHIN 50M OF THE MACHINE WHEN IT IS RUNNING. IN CASE OF WORK IN DENSELY BUILT-UP AREAS, ALL PEOPLE WITHIN THE RISK AREA MUST BE ALERTED.



WARNING!

UNDER NO CIRCUMSTANCES SHOULD THE DRIVER'S SEAT BE LEFT BEFORE THE PTO AND THE TRACTOR'S ENGINE HAS STOPPED COMPLETELY.



WARNING!

NEVER REACH OVER OR WORK NEAR ROTATING PARTS. NEVER TOUCH THESE PARTS WHILE THE PTO AND THE TRACTOR'S ENGINE ARE STILL RUNNING.



WARNING!

THERE IS AN INCREASED RISK OF FIRE WHEN WORKING IN DRY AREAS.

Pay particular attention to the directions below:

- You must read and understand this operator's manual.
- Learn how to operate the machine and how to use the controls properly before operating the machine.
- Follow the safety instructions when operating, adjusting or maintaining the machine.
- Place the machine on a hard level surface when maintaining or adjusting it.
- Turn off the tractor engine and apply the parking brake before cleaning, adjusting, maintaining or mending the machine.
- Do not operate the machine if not all guards and shields for moving parts are in place. Make sure that the work area is clear of all persons and particularly children.
- Insure that the work area is properly lit if you operate the machine after dark.

- If any vibration occurs, stop the engine immediately for further inspection.
- Be careful when raising or lowering the cutting head.
- If the cutting head is in a raised position for cleaning, maintenance, inspection or repair, make sure the position is secured and that the cutting head is blocked. The latch near the joint of the implement secures the frame and the cutting head. The enclosed safety chain should be mounted between the cutting head and the 3-point hitch.
- To ensure that the towing vehicle has sufficient steering and braking, at least 20% of the weight of the towing vehicle must rest on the front axle. If this is not the case, add weights to achieve the correct ratio. See the manual for the tractor.

Also pay attention to the following:

- Unauthorised persons, particularly children, are not allowed near the machine while it is running or is being repaired.
- Do not operate the machine if under the influence of drugs, alcohol or medication.
- Individuals without a proper driver's licence are not allowed to use the machine.
- Never use the machine if the guards for the moving parts, the PTO, or the shafts are removed.
- Never use defective or damaged shaft guards.
- Do not use cardan shafts that do not fulfil the specified requirements.
- Do not perform any adjustments or remove any material from the cutting head/chain rotor while the tractor engine is running.
- Be careful and reduce the speed when working on uneven surfaces.
- Clean the machine thoroughly before repairs or storage.
- Protect hydraulics and coating before performing welding operations on the machine.
- Insure that the area of operation is clear.
- Stop the tractor's engine and the PTO completely before cleaning or servicing the machine. The tractor is parked and the cutting head is lowered to the ground. Make sure that all moving parts have stopped completely.

Use only original repair parts.

Should you require additional information regarding the machine or its operation, contact your authorised dealer or TREJON AB.

2.2 Explanation of the symbols

The warning symbol must always be recognizable. If the warning symbols are missing from your equipment or if they are damaged, replace them at once.

The signs to the right have the following meaning:



Warning!
Read the instruction manual carefully and make yourself familiar with the machine before using it.

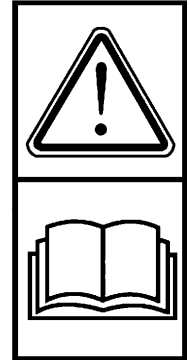

Warning!
Keep hands and feet away from any moving parts. Keep away from the PTO while the engine is running. Failure to follow these instructions can result in serious injury or even death.



Warning!
Objects such as stones and splinters can be discharged while the machine is running. Therefore, keep away from the machine. Maintain a distance of at least 50m from the machine when the engine is running. The operator should have a good view of the work area. Avoid operating the machine in the presence of people and animals or in built-up areas.



Crushing hazard! When connecting, never stand between the tractor and the equipment as long as the tractor is moving. The tractor must be immobilized with the parking brake whenever the operator leaves the cabin.



The machine is designed to operate from 540rpm to max. 1000rpm tractor PTO speed.



Stop the engine and apply the handbrake before cleaning, adjusting, maintaining and repairing the machine.



Greasing point.

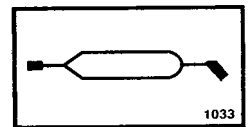

Oil level. Check the oil level and add more oil if necessary. Follow the maintenance instructions when changing the oil.

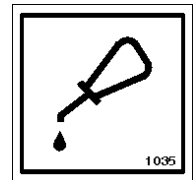

The cutter should only be lifted by these lifting loops!



The CE symbol mounted by the manufacturer confirms that the equipment altogether meets all requirements concerning machinery directives and other corresponding EG directives.

The serial number and model is stamped on the identifying plate (see the picture).

		TREJON AB Företagsvägen 11 SE- 911 35 VÄNNÄSBY, SWEDEN Tel. + 46935- 39900 Fax + 46935- 20241 www.trejon.com	
Serial nr.	<input type="text"/>	Model	<input type="text"/>
Ref.nr:	<input type="text"/>	Weight kg	<input type="text"/>

3 Assembly

When assembling the machine, follow installation instructions below:

- Unpack all parts of the machine and place them on a suitable surface.
- Place the cutting head on a level surface.
- The fixing lugs for the suspension frame and the cutting head are placed between each other. See the picture in the spare parts list.
- Attach the pulleys to the shaft. Make sure that all input parts are on their right places as shown in the picture on the spare parts list.
- Attach the cutting head to the suspension frame by using the double pulley and its shaft.
- Tighten all screws and nuts.
- Install the v-belts. Place the shorter belts on those parts of the machine that have pulleys with a smaller diameter.
- Adjust the v-belt tension properly; if a pressure of about 150Nm (appr. 15kg) is applied to all belts at the same time, they are moved with 15mm from their original position. Also see the section "V-belt tightening".
- Check that the pulleys are aligned, loosen the clamp bushing in order to be able to align the pulleys. See section 4.6.
- Follow all instructions from section 4.1 "Before start-up" before operating the machine.

4 Operating the machine

4.1 Before start-up

Check the following before you operate the machine:

- All screws and nuts should be tightened (inspect all screws and nuts and tighten them if necessary after 4 hours of operation and after that after every fortieth hour of operation. Table 1, page 31 lists the torques for the screws and bolts.
- Make sure that all chains/blades have the same length and dimensions. Also inspect the condition of other parts.
- Check that the v-belts are properly tightened; 150Nm (appr. 15kg) / 4 belts = 15mm deflection. The belts should be tightened **after 10 minutes of operation** (if the machine or the belts are new) and **checked at every eighth hour of operation after that**.
- All pulleys should be aligned. Check the tightening torque (90Nm) of locking screws on the pulleys (2 pcs.) after 4 hours of operation. See chapter 4.6.
- The oil level in the angle gearbox; the oil level on the dipstick should be above the mark located in the upper part of the gearbox. Also see the "Service and maintenance" chapter.

4.2 Mounting variations

The machine is intended for tractors with a 3-point lift of at least cat. II. The standard machine can be both front- and rear-mounted on the tractor. The standard mulcher is intended for rear-mounting on the tractor (pull type).

If the machine is to be front-mounted, adjustments must be made. See section 4.3.

The standard machine is not intended for rear-mounting on a reverse drive tractor with a converted driver's seat; this will cause the chain rotor to rotate in a direction that is not permitted. The mulcher can be delivered adjusted for rear-mounting on reverse drive tractors with a converted driver's seat, see section 4.4.

4.3 Adjusting the machine for front- /rear-mounting

The PTO at the front of the tractor usually rotates in a direction opposite to that of the PTO at the rear of the tractor.

Use a PTO shaft with over running clutch for converted rotational direction (optional) if the implement is to be front-mounted on the tractor. Check the rotation direction of the tractor's PTO when front-mounting the mower.

If the tractor doesn't have a brake on the PTO, a shaft without over running clutch can be used.

The machine is delivered for rear-mounting on the tractor's 3-point lift. If the machine is to be front-mounted on the tractor, the obstacle release mechanism must be moved to the other side of the connection frame.

- Place the implement on a hard level surface.
- Loosen the springs on the appliance and dismantle them.
- Unscrew the screws that go through the springs and keep them in place until it is possible to pull out the lift arm hitch.
- Place the lift arm hitch with profiled tube on the other side of the 3-point hitch frame.
- Reassemble the screws and the springs.
- Tighten the springs until there is a slot of about 1-2mm between the spring coils.
- Lubricate the mechanism with the lubricant nipple.

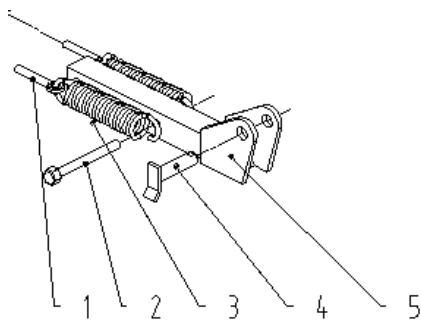

1 – Stretch screw, 2 – Mounting screw, 3 – Springs, 4 – Lift arm pin, 5 – Lift arm hitch point

CAUTION! Use a PTO shaft with free wheels adjusted for converted rotational direction if the tractor's PTO has a brake.

4.4 Adapted machine for reverse drive tractor (optional)

The mulcher can be adjusted for rear-mounting on reverse drive tractors with a converted driver's seat. Such machines are delivered with a gearbox with converted rotational direction and adapted belt guards for the altered rotational direction.

A machine adjusted for a converse driver's seat can only be used at the rear of a reverse drive tractor. If the mulcher is mounted to a tractor in any way other than this, the chain rotor will rotate in a direction that is not permitted.



M-160, Mounted at the rear of a reverse drive tractor.

4.5 Attaching the machine to the tractor



WARNING!

The machine should only be attached to tractors with enough front and rear axle weight so that steering and brakes function correctly after the implement is attached. Use additional ballast if necessary, see the tractor's operation manual.

In order to facilitate the attachment, park the machine so that the left lift arm hitch point is on a stand and is lower than the corresponding right one.

- The implement should only be installed on a hard level surface.
- First attach the left lift arm hitch point of the tractor to the implement and then attach the right arm.
- Adjust the tractor's lift arms so that the implement's frame, with the 3-point hitch, is positioned horizontally.
- Turn off the tractor's engine and apply the handbrake.
- Adjust the length of the PTO shaft, see the instructions that came with the shaft. Pull the shaft apart, and fit the end with the overrunning clutch to the implement. Check that the shaft does not bottom out in any position. (min. play 30mm) and that the sliding part is sufficiently seated in the cuff part (min. 300 mm). If not, shorten the shaft. See the instructions that came with the shaft. Fit the shaft.
- Lubricate and attach the PTO shaft. Insure that the locking pins on the shaft are tight enough. Use the chains to fasten the cardan shaft guards so that they don't rotate.

- The machine can position the top link in 3 different ways. Try to choose a position where the lift arms and the top link of the tractor are parallel. This is to keep the machine parallel to the ground when lifted.

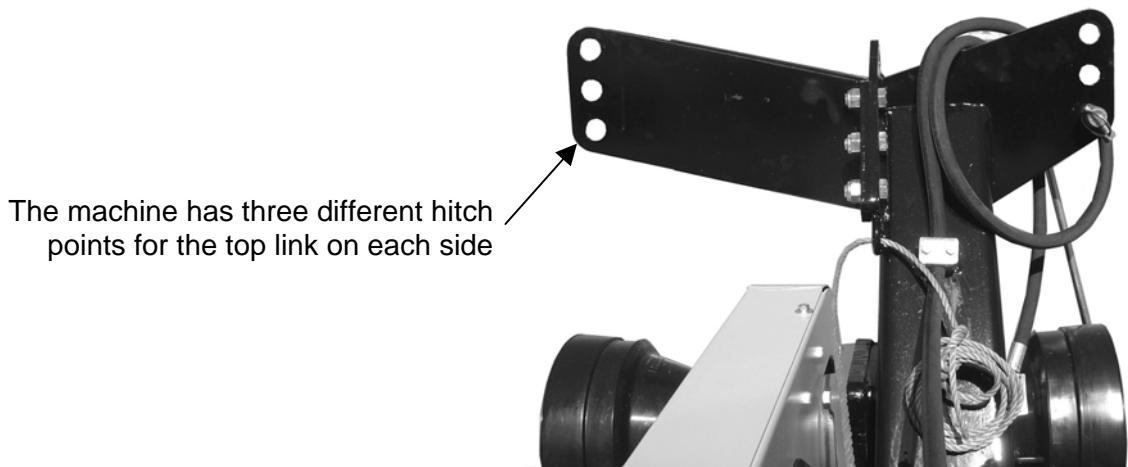

- Mount the top link between the tractor and the machine. Adjust the length of the top link so that the front part is 30-50mm above the ground, depending on the type of surface.

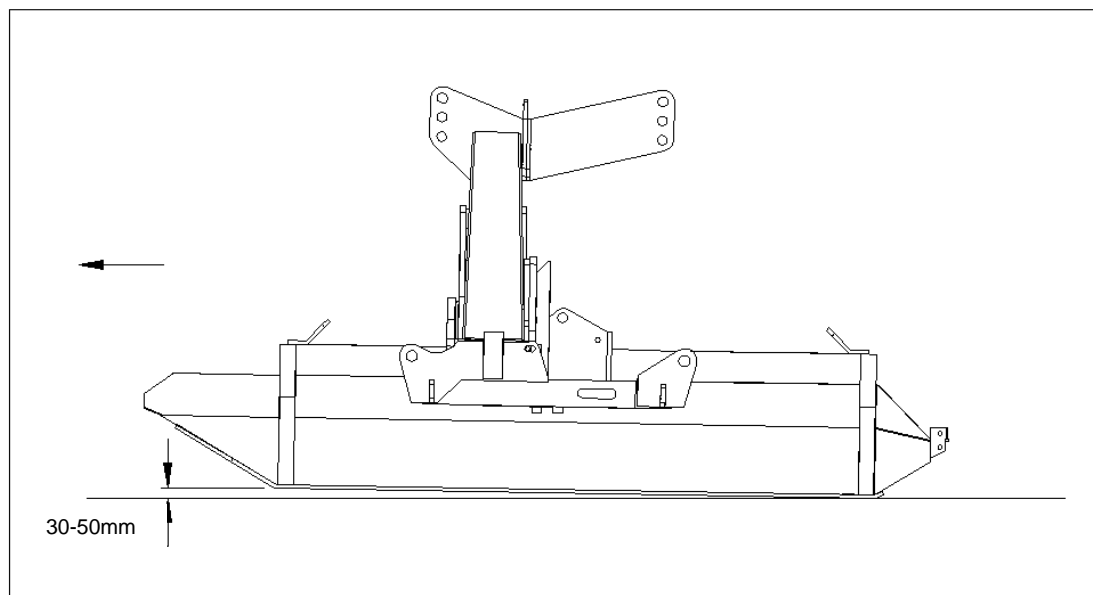

- When the equipment is attached to the tractor, it must be locked sideways with the stabilizer rods.
- Attach the hydraulic tube that raises/lowers the cutting head to one of the single acting outlets on the tractor. Use this cylinder to raise and lower the cutting head while operating the machine.
- Pull in the twine to the transport latch via the tractor's rear window, this way you can unlock and lock the latch from the driver's seat. A longer twine may be needed when the implement is front-mounted.
- Insure that no objects have wrapped around the machine's moving parts.

4.6 Pulleys with “Taper-Lock” clamp bushing

The gearbox and the input shaft pulleys of the machine are attached with clamp bushings. In order to dismantle the pulleys or align the belts, do the following:

Dismantle the belt guards.

Slacken the v-belts by unscrewing the screws on the gearbox and on the 3-point frame.

Dismantle the belts one after another, adjust the pulleys.

Dismantle the pulleys and reconnect them by using Taper-Lock;

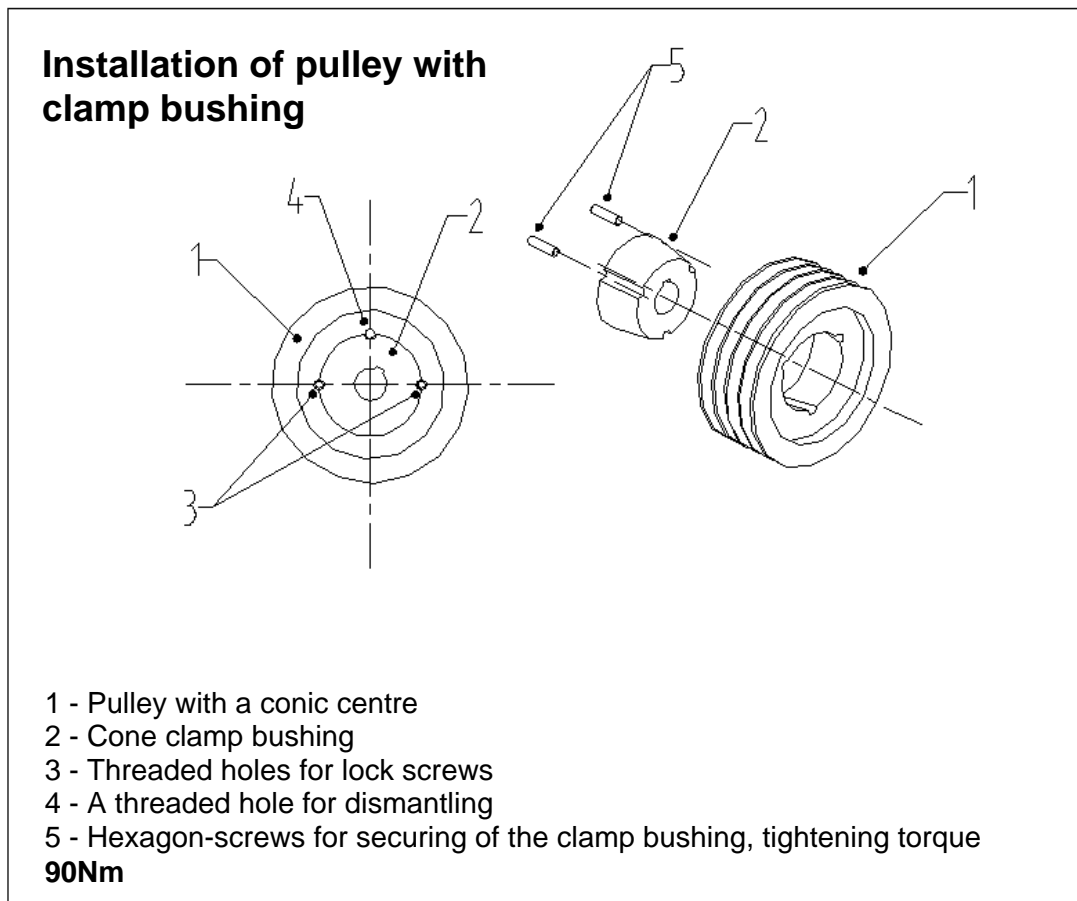

- Unscrew the hexagon-screws (5).
- Install one hexagon-screw in the threaded hole for dismantling (4).
- Tighten the screw slowly until the clamp bushing comes off, tap with a rubber hammer if it doesn't loosen.
- Remove the clamp part (2) from the shaft.
- When reassembling, first insert the pulley (1) above the shaft, and then insert the cone lock.

Lubricate and screw 2 hexagon-screws (5) in their holes (3). Adjust the position of the pulleys roughly and lightly tighten the binding screws. Check if the pulleys are aligned. If they are not aligned, unscrew the lock screws and move the hub on the shaft until the pulleys are aligned. Look at the figure below.

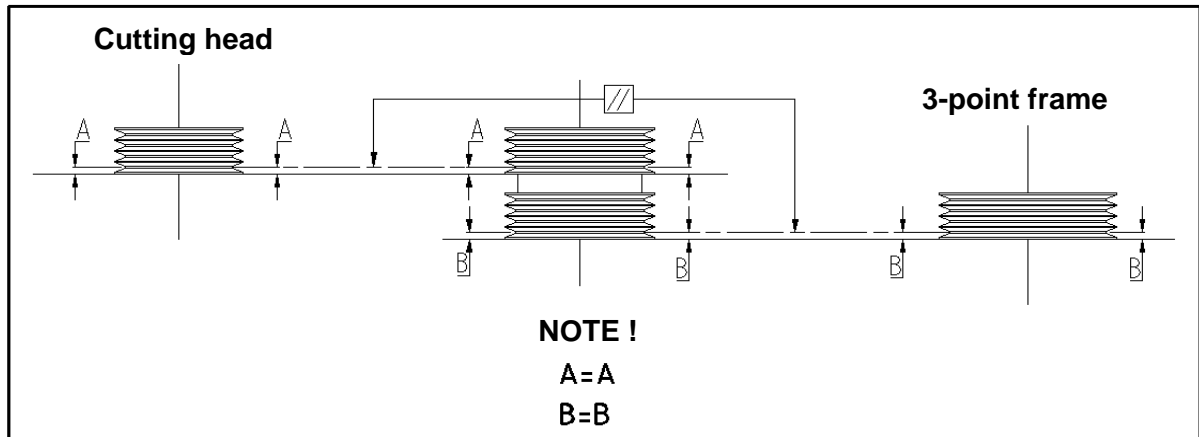

- Tighten the hexagon-screws with **90Nm**. Inspect the lock screws after 4 hours of operation and tighten them if necessary.



CAUTION!

If the machine is new or if the clamp bushing has been dismantled, inspect the screws after the first 4 hours of operation and tighten them if necessary (tightening torque 90Nm).

4.7 Tightening of the transmission V-belts



Tighten new belting after the first 10-20 minutes of operation!

At the start of use, new belts stretch out quickly. It is therefore very important to inspect belt stretch at the beginning. Operating conditions decide how often belt tension should be inspected. It is important to inspect belt tension more often with tough jobs and heavy impact forces.

Tighten the belts immediately if they slip (scream). Belts that are not tightened properly can jump off and damage other belts. Screaming belts can even increase wear on the pulleys.

The above description also applies for new belts.

Follow these instructions when tightening the belting of the 3-point frame:

Unscrew the binding screws (1) of the bearing cage, 4 pcs
with 1-2 rotations of a 24mm
sleeve.



Loosen the nuts (2) that hold the
cardan shaft shield until the shield is
able to glide in the oval holes.

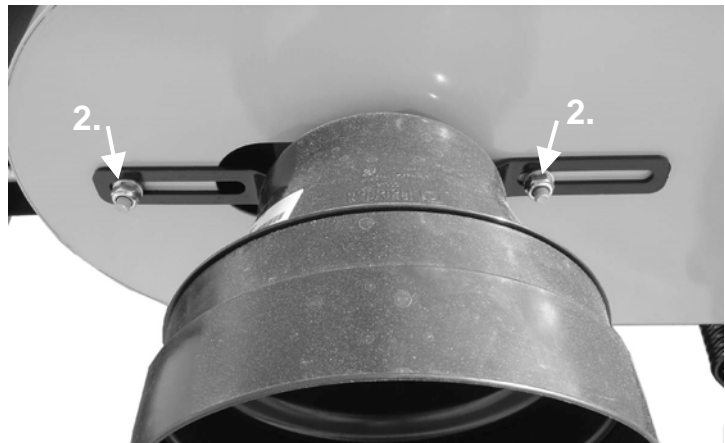

Tighten the belts by turning the nut (3) until proper belt tension is achieved.



The stretch of the belts can be checked with e.g. plate that goes through the slotted hole (4) in the shield.

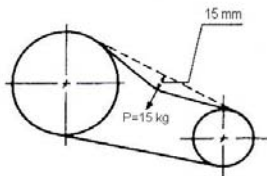

A force of **15kg** applied half-way between the pulleys to **all belts** simultaneously shall deliver a **15mm** deflection.

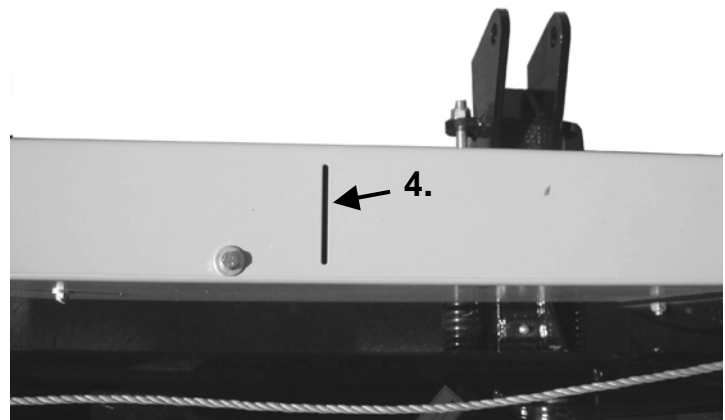

After adjustments are made, move the PTO shaft cover on the v-belt cover so that it doesn't rub against the drive shaft. Then tighten all screws and nuts.



Tighten all binding screws properly after making the adjustments.

Follow the instructions below when tightening the v-belts of the cutting head:

Unscrew the binding screws (1) of the gearbox **1 turn** with a 24mm sleeve.

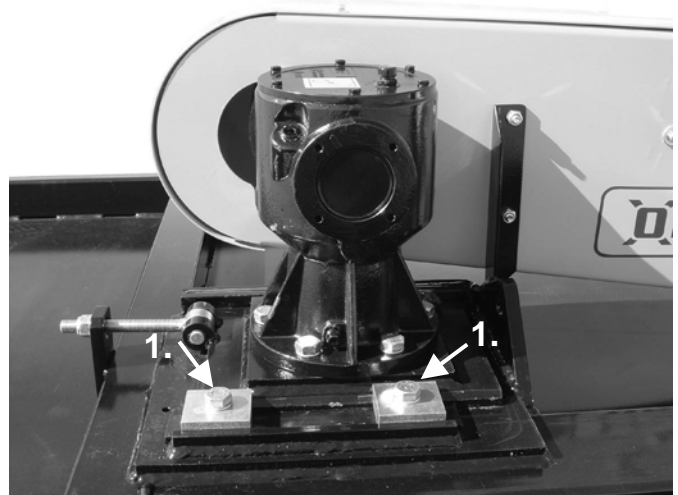

Tighten the belts by turning the adjustment nut (2) until proper tension has been achieved.

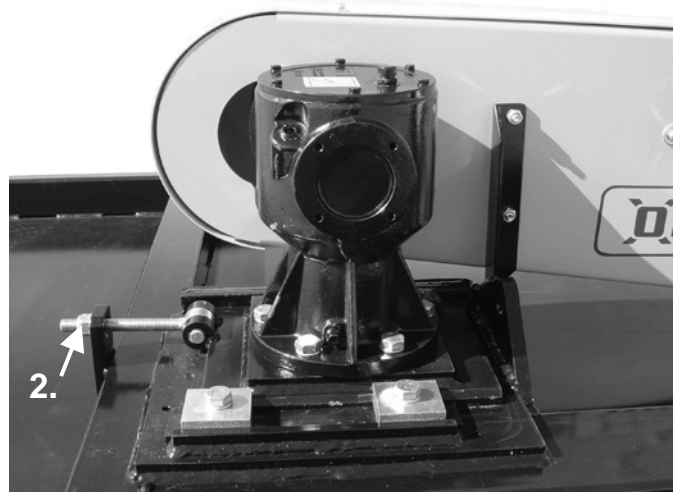

Belt tension can be controlled by e.g. a plate through the slotted hole (3) in the shield.

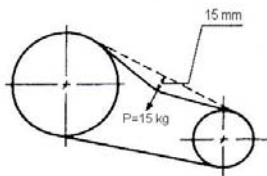

A force of **15kg** applied half-way between the pulleys to **all belts** simultaneously shall deliver a **15mm** displacement.

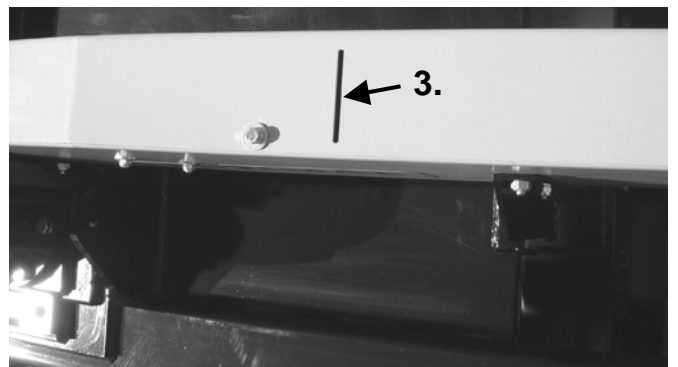

Tighten all binding screws properly after making the adjustments.

4.8 Support rollers for V-belt transmission

The OPTIMAL M-160 is equipped with support rollers for the transmission V-belts. The rollers support the belts during operation. The manufacturer has adjusted the support rollers to give a 10mm deflection on tightened belts. If necessary, adjustments can be made.

The mounting plate on the support roller (1) has slotted holes. Loosen the screws (2) and make adjustments if necessary.

10mm deflection (X) from the original position of tightened belts.

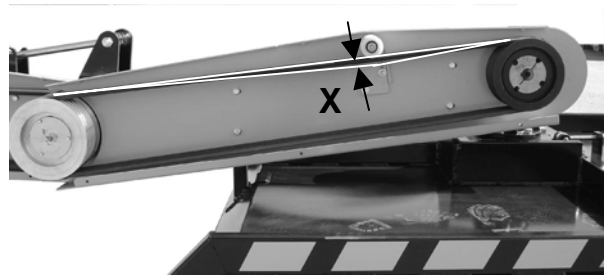
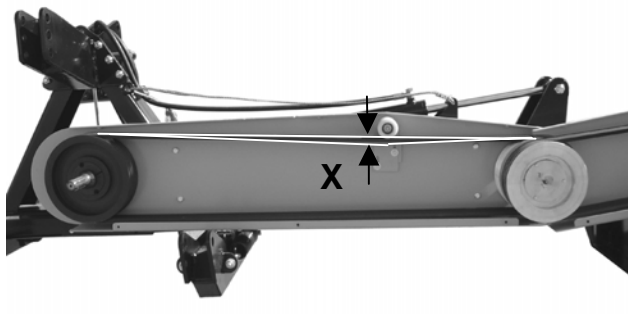
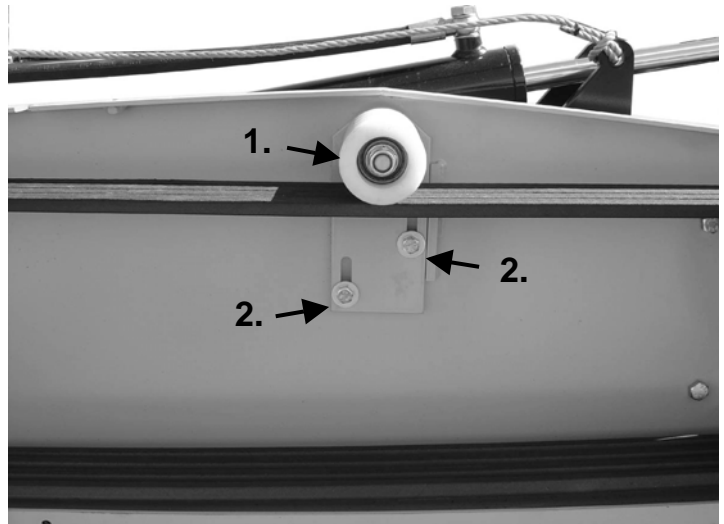

CAUTION!

Don't use the support rollers to tighten the belts. Don't exceed the above dimensions. If the support rollers are adjusted too tightly against the belts, the belts can jump off the rollers and damage belts, backing rollers etc.

4.9 Adjust and change the cutting head chains

The implement is delivered with two types of chains, 10mm and 13mm. The machine is delivered with the 13mm chain assembled in the chain holder. The chains must have the same length outside the chain holder. There can be some spare links inside the chain holder if the chains are new. In case one or more links are missing on a chain, the chain can be rearranged in the holder to achieve equal length. If there are no links left in the holder, the chain must be replaced.

The manufacturer assembles the chains in accordance with the following:

A 13mm chain – 16 links are placed outside the holder.

A 10mm chain – 20 links are placed outside the holder.

After the machine has been in operation and the belt tension has been adjusted a couple of times, the gearbox is also going to move a few centimetres. It is then possible to move one more link (13mm chain) or 2 more links (11mm chain) out of the chain holder.

Follow these instructions when changing or adjusting the chains:

Fold up the cutting head to the transportation position and mount the security chain. Ensure that the latch blocks the joint.

Using a hammer and a mandrel made for 6 mm roll pins, tap in the 4 roll pins. The roll pins must loose completely inside the chain holder housing.

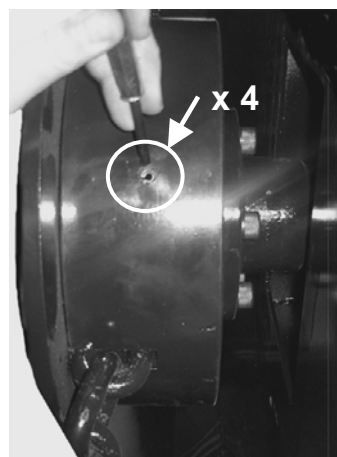

Remove the chain holder's lid.

Move new links forward until the chains have the same length.



Place the lid on the chain holder. Insure that the chains are on their right place.

Install 4 pcs **NEW 6x40mm roll pins (1)** in order to lock the holder.

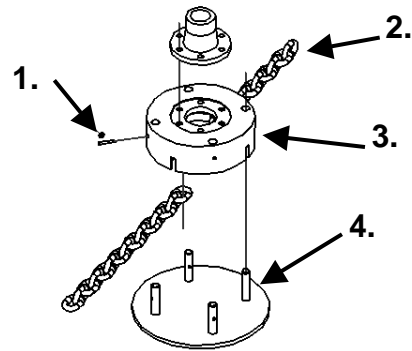

- 1 – Roll pins 6x40 mm
- 2 – Chain
- 3 – Chain holder
- 4 – Lid



WARNING!

**ALWAYS USE NEW ROLL PINS!
NEVER REASSEMBLE USED ROLL PINS!**

USED ROLL PINS CAN LOOSE DUE TO CENTRIFUGAL FORCE. AS A RESULT THE LID AND THE CHAINS WILL ALSO LOOSEN.

Length of new chains:

13mm chain - 25 chain links, 2 pcs chains are delivered with a new machine.

10mm chain - 50 chain links, 2 pcs chains are delivered with a new machine.



Check the condition of all parts that go in the chain holder when adjusting and replacing the chains. Worn or damaged parts must be replaced.



All chains must have the same length. Replace the chains when there are no reserve links left in the chain holder.

Only use chains that have been approved by the manufacturer.



After adjusting, ensure that the chains move freely out of the chassis.

4.10 Installing the blade set

The machine is delivered with a blade set, which can be used for cutting green areas etc.

Follow the instructions below when installing the blade set.

See the instructions in section 4.9.

Dismantle the lid on the chain holder and remove the chains.

Attach the blade set to the chain holder by using 4 pcs. M20x120 screws (2) and M20 Nyloc nuts.

Tighten all retaining screws properly. Insure that the retaining screws on the blades are tightened properly.

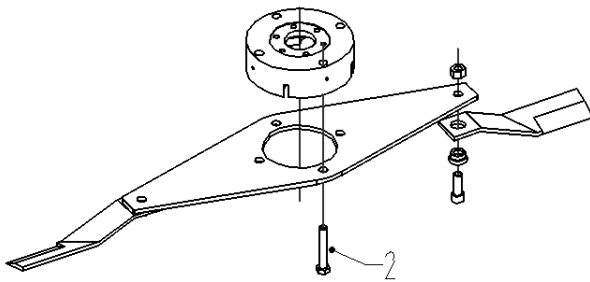

Replacing the blades:

When the blades are worn and their performance is unsatisfactory, the blades must be replaced. If a blade is missing, a new one must be mounted immediately.

Remove the retaining screw and the nut that holds the blade. Install a new blade in the holder and reassemble the screw and nut. Tighten the blade's retaining screws.



Check the condition of all parts that go in the blade holder after replacing the blades. Worn or damaged parts must be replaced.



Use only genuine blades approved by the manufacturer.

4.11 Transport the cutter

Raise the cutter to the transport position and secure it with the chain when transporting the implement to the work area.

Insure that the latch near the joint has been locked, position the hydraulic clutch in the driver's cabin to "neutral".

Dismantle the chain and loosen the latch by using the twine when you want to lower the cutter to the work position.

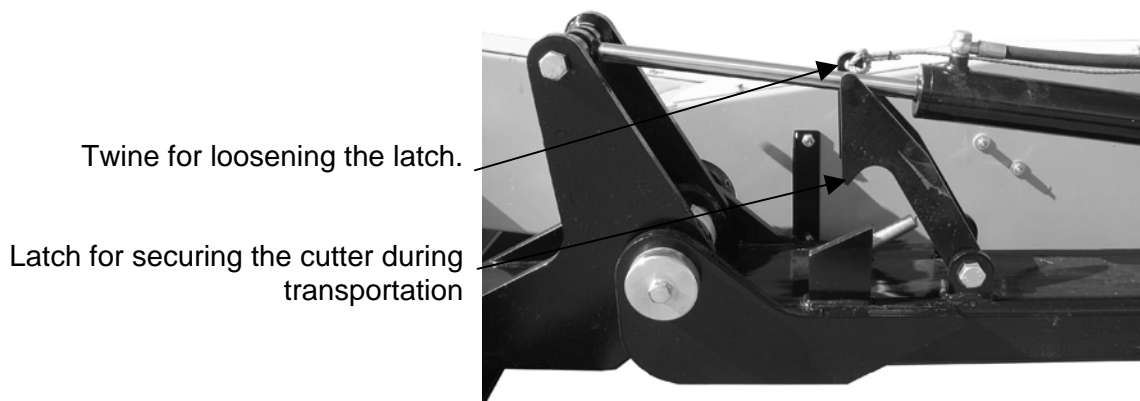

Be careful. Think about the cutter's transport height when it is folded at the back of the tractor.



When the cutter is folded at the back of the tractor the tractor's centre of balance is moved upwards which makes the tractor less stable. Choose your speed with regard to the surface, be careful when cornering.

4.12 Cutting height and tools

Type of material	Tools		
	Blades	10mm chain	13mm chain
Lay lands, fields	+	+	+
Old fields	+	+	+
Old fields with small scrubs	+	+	+
Scrubs and bushes			+
Roadways and ditches			+



CAUTION!
Use the chain when driving across stony areas

Cutting height: 10/13mm chain Appr. 15cm
 Blades Appr. 8cm

4.13 Obstacle release mechanism

The implement is supplied with an obstacle release mechanism that enables the cutting head to move backwards and inside an oval hole in the chassis. The device is spring-loaded which means that it restores its original position after meeting an obstacle. The springs (2) can tighten if the cutter doesn't return to its original position with normal loading. Adjust spring tension by turning the nuts on the hitch points (1).

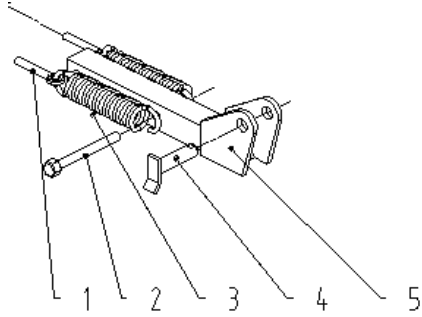

1 – Stretch screw, 2 – Mounting screw, 3 – Springs, 4 – Lift arm pin, 5 – Lift arm hitch point



CAUTION!

THE OBSTACLE RELEASE MECHANISM DOES NOT GUARANTEE THAT THE MACHINE WILL NOT BE DAMAGED IN CASE OF A COLLISION WITH SOLID OBJECTS.

4.14 Operating the implement

**WARNING!**

NO PERSONS OR ANIMALS ARE ALLOWED WITHIN 50M OF THE MACHINE WHILE IT IS IN OPERATION. WHEN PERFORMING CLEARANCE WORK IN DENSELY BUILT-UP AREAS, ALL PERSONS WITHIN THE RISK AREA MUST BE ALERTED.

**WARNING!**

UNDER NO CIRCUMSTANCES SHOULD THE DRIVER'S SEAT BE LEFT BEFORE THE PTO AND THE TRACTOR'S ENGINE HAS STOPPED COMPLETELY.

**WARNING!**

THERE IS AN INCREASED RISK OF FIRE WHEN WORKING IN DRY AREAS.

Hydraulics

A single-acting hydraulic cylinder raises the implement's cutting head. Use the hydraulic lever in the tractor cabin to control the hydraulic cylinder for the cutting head. The lift cylinder is single-acting, which is why the head sinks down by own weight. Because of this there may be problem lowering the head from transportation position when driving in slopes. If this is the case, drive the tractor onto a level surface or turn the tractor around so that the slope facilitates the lowering of the cutting head.

The hydraulic cylinder has a choke near the hose-coupling nipple, which reduces the oil flow and the speed of the cylinder. Thanks to the choke the cutting head is easier to command and its movements are smoother.

PTO speed

It is recommended that you operate the machine from min. 540 rpm to max. 1000 rpm tractor PTO speed.

The number of revolutions can be adjusted within this range depending on the type of material the machine is working with.

- When clearing bushes with the chain, choose a higher speed: 700-1000 rpm.
- If you mow grass with a rough chain, 700-1000rpm is recommended.
- If the machine is working with blade sets or a fine chain on grass or small scrubs choose a lower revolution speed: 540-600rpm.

Work in ditches and roadways

- Adjust the height of the 3-point frame in accordance with the work area. Ensure that the angle of the PTO shaft is not too big; max. 35 degrees.
- Use the lift cylinder on the cutting head to change the height on the implement. Avoid changing the height of the 3-point lift during operation.
- Try to keep the cutting head as near to the ground as possible in order to achieve best results.
- During the clearing of coarse bushes it is recommended that you work over each area more than once with the cutting head set high above the ground. This is in order to achieve better results and avoid stopping of the chain and increased wear on belts.

- Drive carefully when near ditches. The cutting head may get caught and damage the chassis, the cutting head etc.



Working in fields

- Adjust the 3-point frame to a proper cutting height so that the cutting head is held in a horizontal position parallel to the ground.
- Use the lift cylinder on the cutting head to lift the implement. Don't change the height of the 3-point lift during work.
- Try to keep the cutting head as close to the ground as possible in order to achieve the best results.

If the chain mulcher stalls and the belts scream for more than 2 seconds, raise the cutting head for 2-3 minutes to cool down the pulleys. This procedure lengthens the working life of the belts.



CAUTION!

THE OBSTACLE RELEASE MECHANISM DOES NOT GUARANTEE THAT THE MACHINE WON'T BE DAMAGED IF A SOLID OBJECT IS HIT.

4.15 Parking and storing the machine

Park the machine on a level surface with the cutting head down. Lower the stand, and place it so that the left lift arm hitch point is lower than the right. This facilitates the disconnection and reconnection of the machine.

We recommend that the machine is stored under cover. If the machine is to be stored outside and in a lowered position for a long time, apply a coating of grease to the piston rod on the hydraulic cylinder.

5 Service and maintenance



Always turn off the engine and wait until the machine has completely stopped before performing any kind of service or maintenance on the machine. Remove the key from the ignition switch.

Lower the cutting head to the ground.

Keep work area clear of other persons in order to avoid injuries.

5.1 Torque settings

Use the table below for the correct torque settings of bolts and nuts of the equipment.

Table 1 – Torque settings

Diameter	Class 8.8		Class 10.9	
	Nm	lb.ft.	Nm	lb.ft.
M8	25	18	35	26
M10	50	37	70	52
M12	90	66	125	92
M14	140	103	200	148
M16	215	155	305	225
M18	295	217	420	309
M20	420	302	590	438

Increase the torque by 5% when using a locknut

5.2 Inspections and service measures after the first operation hours

The following points need to be carried out on a new machine:

After the first 10 minutes of operation:

- Check and tighten all v-belts. See section 4.7

After the first 4 hours of operation:

- Check the binding screws' tightening torque on the pulleys' clamp bushings. See section 4.6
- Check the bolts and nuts of the machine and tighten if necessary.

After the first 8 hours of operation:

- Perform the 8-hour scheduled service and maintenance routine in accordance with the timetable below.

5.3 Scheduled inspection

Service point	Interval	Lubrication	*Measure	Lubricant	Note
Transmission V-belts	8th hour	-	A/I	-	See section 4,7
Cardan shaft PTO "Universal cardan joints"	8th hour	Yes	I	Grease NLGI 2	See the cardan shaft instructions
Cardan shaft PTO "Profile tubes"	8th hour	Yes	I	Grease NLGI 2/Oil 10w30	See the cardan shaft instructions
Cardan shaft PTO "overrunning clutch"	8th hour	Yes	I	Grease NLGI 2	See the cardan shaft instructions
Cardan shaft PTO "Locking pins"	8th hour	Yes	I	Oil	See the cardan shaft instructions
Slide bearing at the joint	8th hour	Yes	I	Grease NLGI 2	
Obstacle release mechanism	8th hour	Yes	A/I	Grease NLGI 2	
Bolts and nuts	40th hour	-	I/A		Follow Table 1 – Torque settings
Chains/chain holder	40th hour	-	I/A/C	-	
Input shaft bearing 2 pcs	40th hour	Yes	I	Grease NLGI 2	
Idler pulley bearings	40th hour	Yes	I	Grease NLGI 2	
Angle transmission gearbox	40th hour	-	I	SAE 80W90 API GL4/GL5	
Angle transmission gearbox	First 50 hours, then after every 500th hour	Oil change	Ch	SAE 80W90 API GL4/GL5	1.7 litres

***Key: A=Adjustment, I=Inspection, C=Cleaning, Ch=Change**

Use grease NLGI 2 with EP-qualities for lubricating.

Do NOT use "graphite-grease" for the ball bearing. Don't use a pneumatic grease gun to lubricate sealed bearings; the seal can loosen or be damaged.

These intervals apply to normal conditions. In case of continuous operation, lubricate more often. Always lubricate after cleaning with water.

5.4 Checking the angle gearbox oil level

Check the oil level when the gearbox is cold and has been stored lowered onto a level surface.

Loosen the air nipple on top of the gearbox. There is a dipstick on the gearbox. The oil level should be above the mark on the gearbox dipstick. The gearbox is filled with SAE80W90 API GL4/GL5. Add oil through the air nipple on the top side of the gearbox if necessary.

Breather-/oil fill-nipple with dipstick

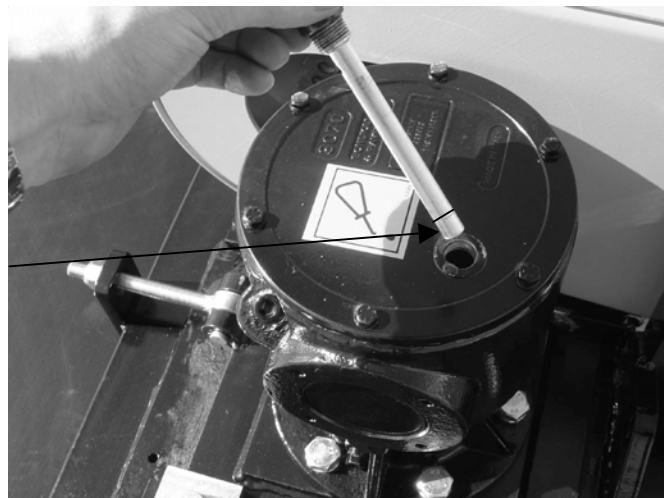

5.5 Oil change in the angle gearbox

The oil in the gear box must be changed after the first fifty hours of operation, after that at every five hundred hours or at least once a year.

Breather-/oil fill-nipple with dipstick

Oil drain plug

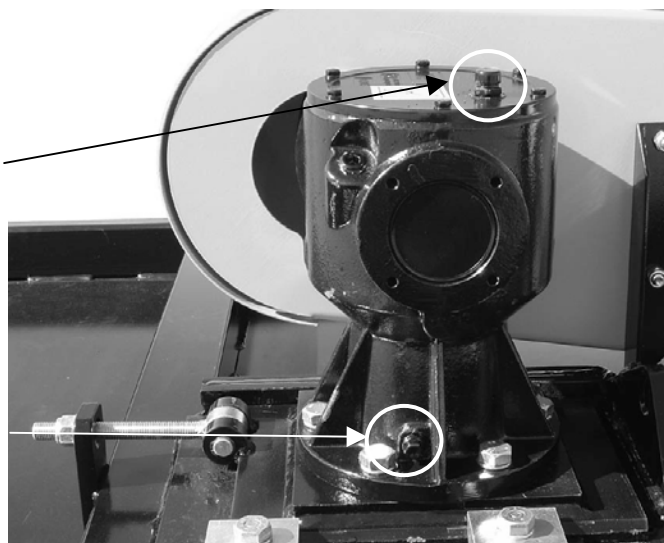

**Oil: SAE80W90 API GL4/GL5.
Volume: 1.7 litres per change.**

Start the PTO and keep the machine running until the gearbox gets warm. Unscrew the breather-nipple on the upper part of the gearbox. Drain the oil into a vessel by using the drain plug on the lower part of the gearbox. Tighten the plug. Add oil until the oil lever reaches the mark on the dipstick. **Let the oil sink in the gearbox bearings before you read the oil level.** After reaching the correct oil level, tighten the breather-nipple and dry any oil spills.

Note! Dispose of the old oil in an environmentally friendly way and in accordance with current regulations in your country!

5.6 Before the season starts

Go through all the above instructions. The care you give to your implement will greatly determine your satisfaction with its performance and its service life.

5.7 After the season ends

Clean the machine thoroughly, then lubricate and have it serviced. If the machine dries up, we recommend applying a thin layer of oil on the places where the colour has worn off.

6 Troubleshooting

Problem	Probable cause	Measure
Unsatisfactory results when the chain is mounted.	<p>The rotation speed is too low.</p> <p>V-belts are slipping.</p> <p>Worn v-belts.</p> <p>Worn chain, missing links.</p> <p>Chain too light with regard to vegetation.</p> <p>The travelling speed is too high.</p>	<p>Keep the rotation speed between 540 and 1000rpm. Tighten the belts as described in section 4.7. Replace belts.</p> <p>Replace a chain or adjust the length. See section 4.9.</p> <p>Use a 13mm chain with bushes/lay land.</p> <p>Choose a lower gear or keep the cutting head high and drive through the same area several times.</p>
Unsatisfactory results when the blades are mounted.	<p>The PTO speed is too low.</p> <p>V-belts are slipping.</p> <p>Worn v-belts.</p> <p>Worn blades, a blade is missing.</p> <p>The vegetation is too coarse.</p> <p>The speed is too high.</p>	<p>Keep the rpm speed between 540 and 1000rpm. Tighten the belts as described in section 4.7. Replace belts.</p> <p>Replace blades, ensure that both blades are attached. See section 4.10. Use a chain instead.</p> <p>Choose a lower gear or keep the cutting head high and work the area several times.</p>
Vibration during operation.	<p>The chains do not have identical lengths.</p> <p>Blades are missing or have come off.</p> <p>The angle of the cardan shaft PTO is too big.</p>	<p>Adjust the lengths of the chains so that they are identical.</p> <p>Mount new blades.</p> <p>Lower the 3-point on the tractor in order to reduce the angle on the universal cardan joint.</p>

7 Spare parts list



Contact the authorised dealer where you purchased the machine when you wish to order spare parts or need other assistance.

When you are ordering spare parts, make sure you know the model, type and serial number of the machine. See the plate on the chassis.

7.1 Cutting head and transmission

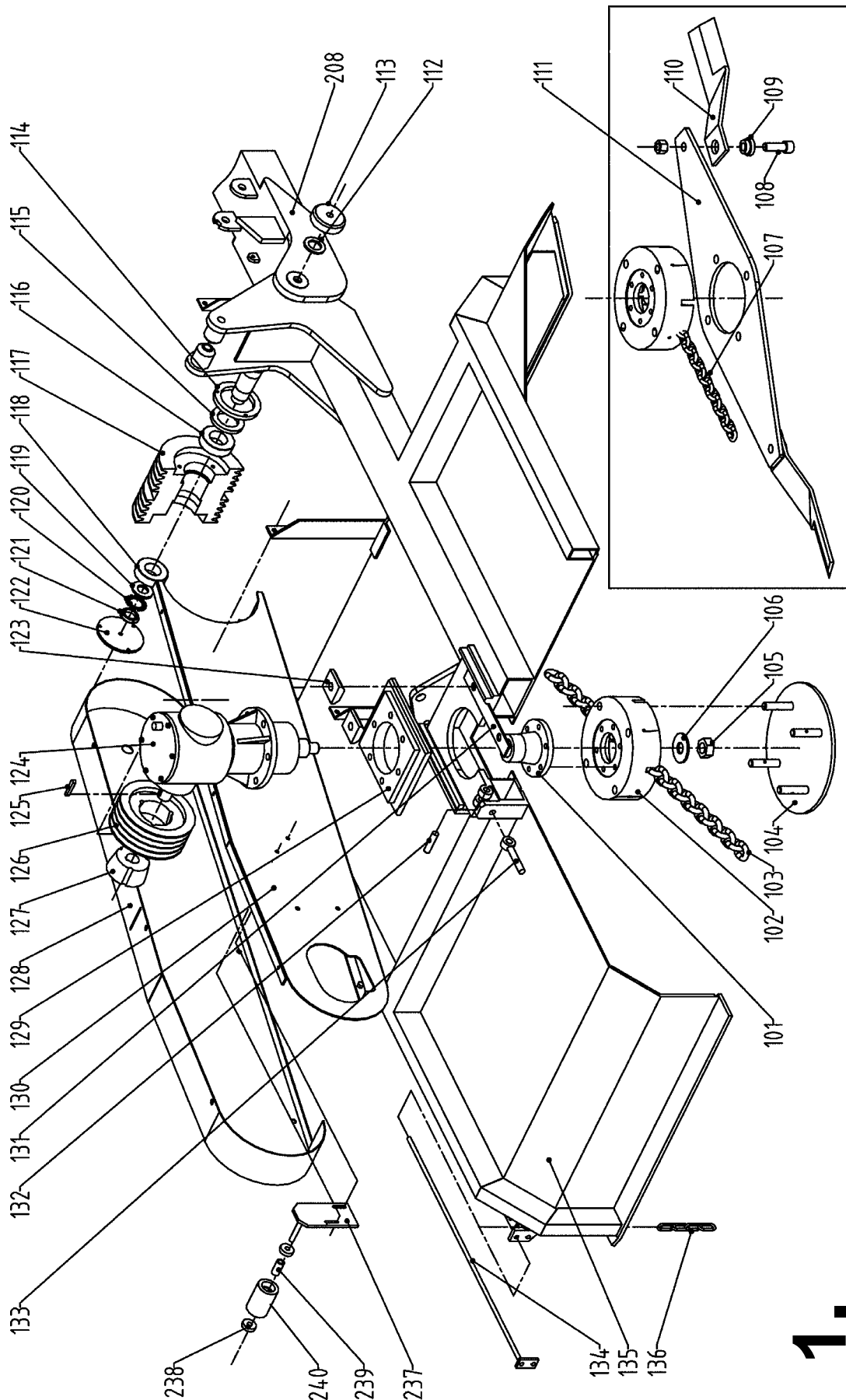

Ref	Pos	Description	Art. No	Quantity	Accessories	Quantity	Notes
1	101	Mounting flange 298104502	298104502	1			
1	102	Cutting head	46 501	1	Screw M12x45 12.9 Nut Nylock M12	6 6	
1	103	Chain d=13 25-links KET 138	46 504	2			
1	104	Lid	46 805	1	Cylindrical rollpin D 6x40	4	
1	105	Nut Nylock M30	46 724	1			
1	106	Washer 58/30,5 x 5	46 407	1			
1	107	Chain d=10 25-links KET 108	46 505	2			
1	108	Screw M20x60 hexagon head 12.9	M20x60 12.9	2	Nut Nylock M20	2	
1	109	Bushing 45/21 x 23	46 723	2			
1	110	Blade	46 722	2			
1	111	Blade holder	46 721	1	Screw M20x120 Nut Nylock M20	4 4	
1	112	Distance washer 42/17x4	42/17 x 4	1			
1	113	Lid	46 405	1	Screw M16x60 Spring washer 16	1 1	
1	114	Seal retainer	46 411	1	Screw M6x25 Spring washer 6	3 3	
1	115	Stopping 60x95x10 AS	60x95x10	1			
1	116	Bearing 32210 A	32210	1			
1	117	Pulley 236x8	46 402	1			
1	118	Bearing 32209 A	32209	1			
1	119	Washer 58/36 x 5	46 409	1			
1	120	Lock washer MB7	MB7	1			
1	121	Nut M35x1,5 KM7	M35 x 1,5	1			
1	122	Sectional plate	46 406		Screw M6x20 Spring washer 6 Lubricant nipple M10-1	3 3 1	
1	123	Fixing wedge	46 601	2	Screw M16x1,5 L=50mm Spring washer 16	2 2	
1	124	Gearbox	3070125015	1	Screw M16x40 Spring washer 16	6 6	
1	124	Gearbox	3070.125.019	1			For converted rotational direction (reverse drive tractor)
1	125	Wedge 10x8x50	46 410	1			

Ref	Pos	Description	Art. No	Quantity	Accessories	Quantity	Notes
1	126	Pulley SPB-200-4	SPB 200-4	1			
1		V-belt SPB 3450	SPB 3450	4			
1	127	Clamp bushing "Taper lock" TL3020-35	TL 3020-35	1	Screw 5/8" x 32 hexagon head	3	
1	128	V-belt cover	46 833	1	Screw M8x20 Spring washer 8 Washer 24/9 x 2	6 6 6	
1	128	V-belt cover	46 851		Screw M8x20 Spring washer 8 Washer 24/9 x 2	6 6 6	For converted rotational direction (reverse drive tractor)
1	129	Gearbox mounting plate	46 824	1			
1	130	V-belt cover	46 832	1	Screw M10x25 Nut Nylock M10 Washer 20/11 x 2	4 4 2	
1	130	V-belt cover	46 850		Screw M10x25 Nut Nylock M10 Washer 20/11 x 2	4 4 2	For converted rotational direction (reverse drive tractor)
1	131	Plate	46 619	1			
1	132	Pin	46 620	1	Clamp ring A16	2	
1	133	Stretch screw	46 823	1	Washer 30/17 x 3 Nut Nylock M16	1 1	
1	134	Link	46 818	2	Screw M10x30 Nut Nylock M10	2 2	
1	135	Cutting head	46 821	1	Lubricant nipple M10x1		
1	136	Chain guard d=6 4-links KETPH 06	46 722	40			

7.2 Suspension frame and transmission

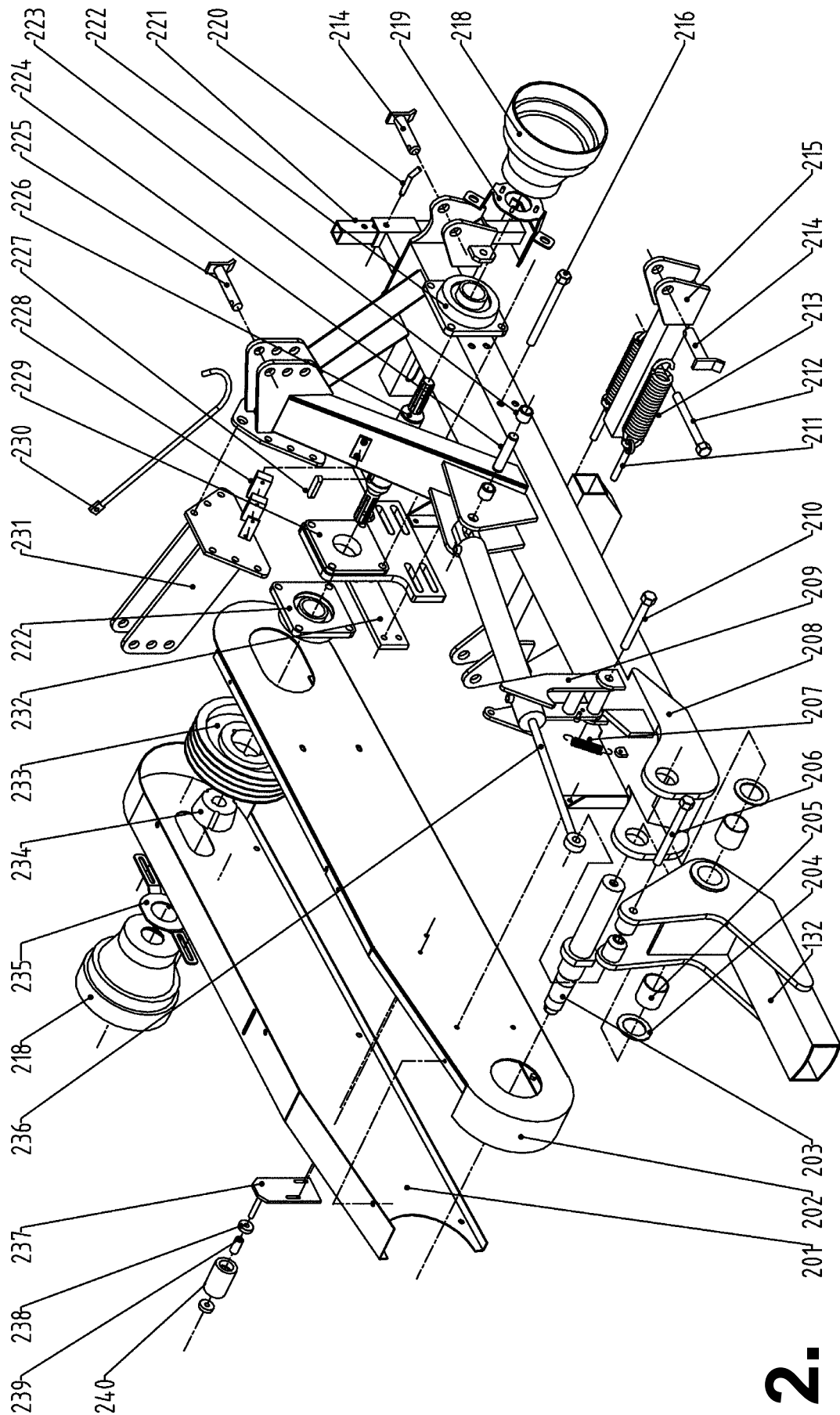

2.

Ref	Pos	Description	Art. No.	Quantity	Accessories	Quantity	Notes
2	201	V-belt cover	46 835	1	Screw M8x20 Spring washer 8 Washer 24/9 x 2	6 6 6	
2	201	V-belt cover	46 853	1	Screw M8x20 Spring washer 8 Washer 24/9 x 2	6 6 6	For converted rotational direction (reverse drive tractor)
2	202	V-belt cover	46 834	1	Screw M10x25 Washer 20/11 x 2 Nylock M10	4 2 4	
2	202	V-belt cover	46 852	1	Screw M10x25 Washer 20/11 x 2 Nylock M10	4 2 4	For converted rotational direction (reverse drive tractor)
2	203	Shaft	46 803	1			
2	204	Washer 90/61 x 2,5	46 408	2			
2	205	Bronze bushing BRM80 60x65x70	BRM80	2			
2	206	Screw M20x200	M20x200	1	Nylock M20	1	
2	207	Draw spring d=3 Dy=21 L=95	KM01801	1			
2	208	Frame	46 822	1	Lubricant nipple M10x1	2	
2	209	Safety lock	46 811	1	Cylindrical pin 8x40	1	
		Nylon cord L=3000	46 726	1			
2	210	Screw M20x160	M20x160	1	Nylock M20	1	
2	211	Stretch screw	46 809	2	Nylock M16 Washer 30/17x3	2 2	
2	212	Screw M20x180	M20x180	1	Nylock M20 Washer 36/21 x 3	1 2	
2	213	Draw spring SF-DF 3636	SF-DF 3636	2			
2	214	Pin	42 110	2	Ring cotter 11	2	
2	215	Lift arm hitch point	46 808	1			
2	216	Screw M16x220	M16x220	4	Spring washer 16	4	
2	218	Cardan shaft shield (PTO 41703)	41703	2	Nylock M8 Washer 24/9 x 2	8 8	
2	219	Holder	46 817	1			
2	220	Cotter	10 609	1	R-pin d=4	1	
2	221	Stand	18 825	1			
2	222	Bearing UCF212	UCF 212	2			
2	223	Bushing 35/26 x 29	46 608	2			

Ref	Pos	Description	Art. No.	Quantity	Accessories	Quantity	Notes
2	224	Pin	46 615	1	Clamp ring A25	2	
2	225	Pin	42 109	1	Ring cotter 11	1	
2	226	Shaft	46 401	1	Clamp ring A60 Distance washer 75/60 x 1	2 2	
2	227	Wedge 18x11x50	46 412	1			
2	228	Hydraulic tube holder AD 16		1	Screw M6x40	2	
2	229	Mounting plate	46 806	1	Screw M16x100 Nylock M16 Washer 30/17 x 3	4 5 1	
2	230	Hook	46 827	1	Screw M10 x 30 Nylock M10	1 1	
2	231	Top link hitch point	46 810	1	Screw M16x40 Nylock M16	6 6	
2	232	Mounting plate	46 607	1			
2	233	Pulley SPB-280-4	SPB 280-4	1			
		Belt SPB 3650	SPB 3650	4			
2	234	Clamp bushing "Taper Lock"TL3020-60	TL 3020-60	1	Screw 5/8" x 32 Hexagon head	3	
2	235	Holder	46 816	1	Nylock M10 Washer 24/11 x 2	2 2	
2	236	Cylinder HC-60-25-600	HC-60-25-600	1	Stopping 300-06 Stopping 300-08 Quick coupling 3020-08 Dust cap 1020-08 Screw BR-3/8" H-tube 7015-3/8\ 3/8"- 2500\40-8-6	2 1 1 1 1 1	
2	237	Holder	46 820	2	Screw M8x25 Nylock M8 Washer 16x8,5x1,5 Nylock M12	4 4 4 2	
2	238	Bearing 6301	6301	4			
2	239	Bushing	46 415	2			
2	240	Backing roller	46 414	2			
		Chain guard d=8 60-links KETL H08	46727	1	Shackle SAK 08KL	2	



EC-Certificate of Conformity

conforming to EEC Directions 98/37/EG

We **TREJON FÖRSÄLJNING AB**
 (name of supplier)

SE – 911 35 Vännäsby, Företagsvägen 9

 (full address of company – where this concerns authorized agents within the Common Market, also state the company name and manufacturer)

declare in sole responsibility, that the product

Chain Mower OPTIMAL M-160

 (make, model)

to which this certificate applies, conforms to the basic safety and health requirements of EEC Directions 98/37/EG,
 (if applicable)
 and to the other relevant EEC Directions.

— — —

 (title and/or number and date of issue of the other EEC Directions)

(if applicable)
 To effect correct application of the safety and health requirements stated in the EEC Directions, the following standards and/or technical specifications were consulted:

EN ISO 12100-1 : 2003 EN ISO 12100-2 : 2003

 (title and/or number and date of issue of standards and/or specifications)

Vännäsby, 01.01.2004

 (Place and date of issue)

Håkan Johansson
Managing Director

 (Name and job function of authorized person)

Warranty- / assignment certificate

Warranty terms

- | | |
|-----------------------------|--|
| General about warranty | - The TREJON-warranty is limited by the conditions mentioned below and by the specific warranty terms issued by the supplier. These terms are in such cases attached to the operators manual for each machine. |
| Validity of warranty | - Where the machine is bought for private use, the warranty provided by TREJON is valid for 12 months as of the date of purchase.
- In case of commercial use for 3 months. |
| The warranty cover | - Damaged parts, which have broken down because of defective production operations of materials in course of <u>normal use of the machine</u> .
- The work-related expenditures, of the replacement of faulty spare part under the warranty, are compensated according to the official price-list of TREJON. TREJON may review the time for repair and adjust it to a average time of other dealers to make similar repairs. |
| The warranty does not cover | - Transport costs applicable to the machine or the parts.
- Travel costs.
- Possible costs that have been caused by the failure of the machine.
- If the machine has been modified by the owner.
- Faults, which have been caused by the machine's normal wear and tear and are not related to production faults.
- Inexperienced use or use of spare parts, which are not original.
- The warranty is not applicable to parts which are subject to wear, for example hoses, sealing, oil, belts, batteries, chains, knives etc. |
| Warranty procedures | - Before you start large warranty works, contact TREJON AB.
- In case you want the warranty to be valid, the TREJON warranty claim must be completed and returned to TREJON AB no later than within 3 weeks after the repair have been carried out. Return of exchanged parts should only be sent on demand. |
| ATTENTION! | The warranty becomes valid after the WARRANTY / ASSIGNMENT CERTIFICATE has been completed and returned to TREJON within 14 days after the date of purchase. |

Assignment certificate:

The buyer of the machine hereby verifies with his/her signature of having admitted the manual and studied it and been provided with the necessary driving instructions and passed after-delivery control.

PLEASE FILL IN!



Product: _____	Serialno: _____
Salesman: _____	Company: _____
Signature of salesman: _____	Date of purchase: _____
Name of buyer: _____	Telephone: _____
Adress: _____	Postcode: _____
City: _____	Country: _____
Date: _____	Signature of buyer: _____

Spare parts

Your choice is between “original” or “copies”!
Price is often the deciding factor. A “cheap” choice may well be an expensive one in the end.

Some reasons to choose TREJON spare parts:

- Quality and fit.
- Reliability
- Longer service life and therefore better economics
- Guaranteed availability through the TREJON sales partners

The TREJON original spare parts are specifically made for this equipment. The fitting and/or use of non-original parts and accessories may change the technical qualities of your equipment in a negative way. The manufacturer does not give any guarantee for damages caused by using non-original parts or accessories.

The guarantee does not cover arbitrary changes made on the equipment.

TREJON AB reserves the right to change or to improve shown models using technical or commercial reasons, without demands to carry out the same improvements on equipment already delivered. Pictures in the manual do not necessarily show the equipment as delivered.

Technical data, weights and measures are without obligation. Reservation for faults.

© 2005 Trejon AB, Sweden

Copying, translation and excerpts are only permitted with a written permit from TREJON AB, Företagsvägen 9, SE – 911 35 Vännäsby.

All rights reserved.



TREJON AB
Företagsvägen 9
SE-911 35 VÄNNÄSBY
SWEDEN
Tel: + 46 (0)935 39 900
Fax: + 46 (0)935 39 919

